



# Sentrack™ Track Monitoring System



## A COMPLETE RAILWAY SENSOR SOLUTION

The Metrom Rail SenTrack™ Track Monitoring System (STS) provides a complete detection package for monitoring the most prevalent hazardous railway conditions.

The STS combines critical rail-mounted sensor technology with an advanced control system which monitors all systems and broadcasts customized warnings over a local radio channel or by wireless modem.

The system can be ordered and installed with any combination of Metrom Rail-supplied sensor solutions. The STS arrives on-site as a finished system, including all pre-wired electronics in the supplied enclosure.

With a robust design and modular components, the STS is suitable for use in any location and application. For an overall degree of protection, a system can be fitted with a wide array of sensors performing different functions. For a more specific detection role, a system can be outfitted with many versions of the same sensor. For example, multiple Track Integrity Sensors may be placed in an area leading to and surrounding a bridge.

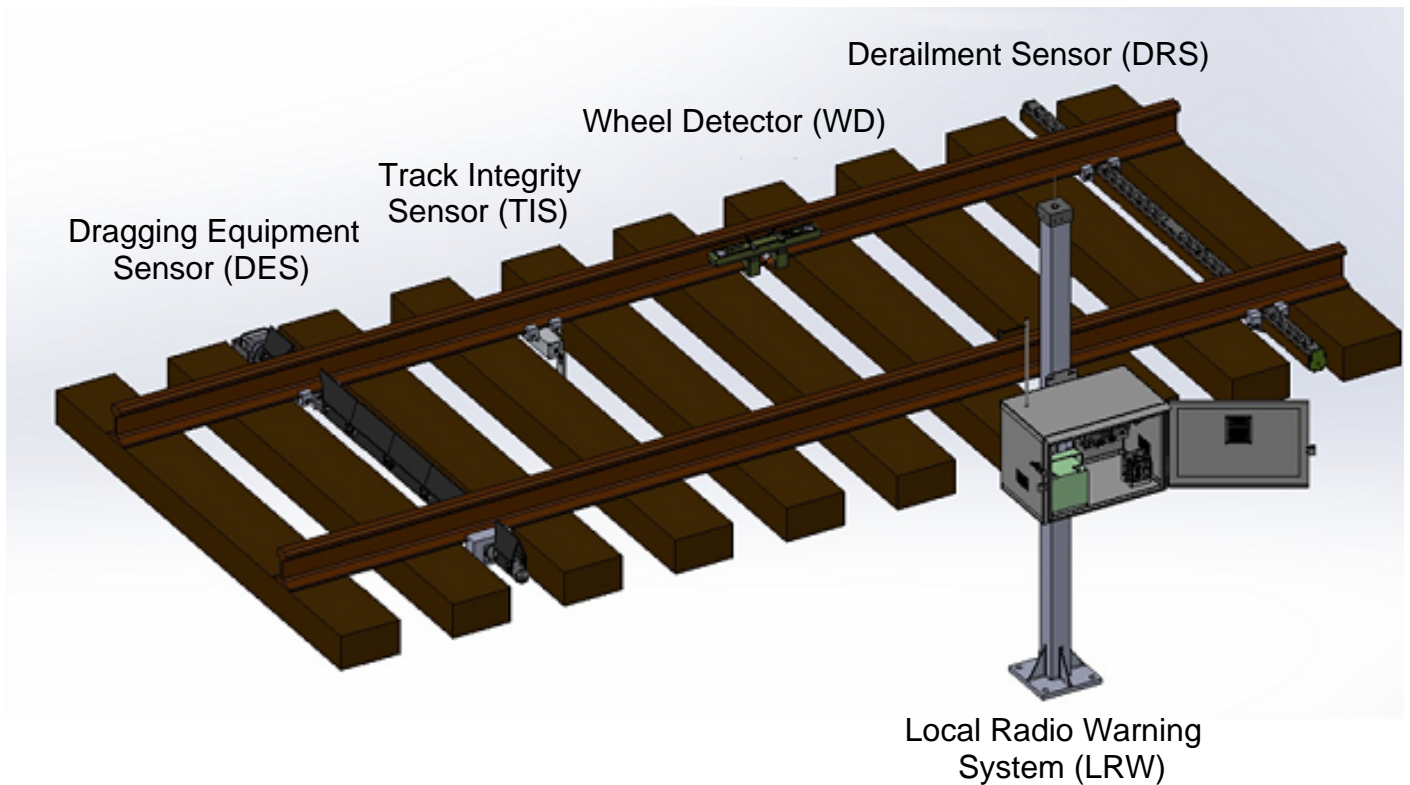



# SenTrack™ Track Monitoring System



## SYSTEM ELEMENTS: LRW



- **LOCAL RADIO WARNING SYSTEM (LRW)** – The LRW serves as both the command center and communications suite for all sensors integrated into the STS system. An interface board allows operators in the field to easily program basic parameters of operation for the suite. Emergency signals are broadcast over a 5-mile radius in the case of sensor activation. The LRW is comprised of the following elements:



## LRW COMPONENTS:

- **INPUT SURGE PROTECTION MODULE** – 8-position ganged surge protection module utilizes quick release Wago terminal block, and has been designed to exceed all AREMA standards.

**Metrom Rail Part Number:** FA-1067



- **CONTROL UNIT** - Features a 2 x 20 alpha-numeric display for programming and diagnostics, USB port for software updates or data retrieval, unit health monitoring LED, and 32MB of message storage, all contained within an aluminum housing.



- **BATTERY CHARGER** – The LRW battery charger features an integrated heat sink housing design, remote temperature monitoring and compensation for more efficient battery charging during temperature extremes, built in diagnostics for battery and charging monitoring, and wide temperature range of -40C to +85C.

**Metrom Rail Part Number:** FA-1071



# Sentrack™ Track Monitoring System



## SYSTEM ELEMENTS: SYSTEM SENSORS



- **DERAILMENT SENSOR (DRS)** – A Metrom Rail DRS is designed to detect local wheel derailments by fracturing under the weight of a misaligned wheel. The fracture will open an electrical circuit which is interpreted by the LRW.

**Metrom Rail Part Number:** FA-1035

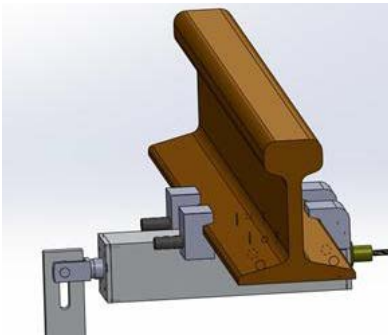

- **TRACK INTEGRITY SENSOR (TIS)** – The TIS is a sensor secured to both the rail and an embedded ballast probe. In the case of rail deformation or ballast washout, the sensor will immediately send an alarm activation to the LRW for broadcast. The TIS ensures that sensitive locations, such as bridges, can be monitored at all times.

**Metrom Rail Part Number:** FA-1054

(available Q2, 2013)



- **DRAGGING EQUIPMENT SENSOR (DES)** – The Metrom Rail DES is a replacement for long-standing Dragging Equipment Sensor technology. The rail-mounted DES is constructed of a light-weight composite body, and a quick-assemble/disassemble design allows for a single operator to easily remove the device from a rail. The DES comes with programmable null points, and can detect the speed at which the sensor is struck and in what direction. All details are reported by the LRW system, over an open emergency channel.

**Metrom Rail Part Number:** FA-1053

(available Q2, 2013)



- **WHEEL DETECTOR (WD)** – The WD is a wheel detection module which interprets axle counts, speed and direction of a vehicle. When an alarm is triggered by any of the sensors in the system, the axle count is added to the verbal announcement, giving operators an idea of exactly where to look for a problem.

**Metrom Rail Part Number:** FA-1041

- **ANEMOMETER (WS)** – Wind speed sensor which is mounted to the supplied 4" square aluminum tower utilizing a supplied bracket.



# Sentrack™ Track Monitoring System



## SYSTEM SPECIFICATIONS

|                                   |  |
|-----------------------------------|--|
| <b>Metrom Rail Part Number:</b>   | Single Track: FA-1055 / Double Track: FA-1056  |
| <b>Input Voltage:</b>             | 110VAC   |
| <b>Operating Temperature:</b>     | -40C to +85C   |
| <b>Recommended Foundation:</b>    | Dixie Precast DPS-1A 3' 7"   |
| <b>Mounting Pattern:</b>          | 9.5" x 9.5" – 1.125" dia. holes  |
| <b>Radio Surge Protection:</b>    | PolyPhaser IS-B50HN-C2   |
| <b>Supplied Mounting Mast:</b>    | 4" x 4" x 8' aluminum – TIG welded with 24" copper ground pigtail  |
| <b>Standard Available Inputs:</b> | (2) legacy dragging equipment sensors<br>(3) Metrom Rail Dragging Equipment Sensors (DES)<br>(9) Metrom Rail Derailment Notification Sensors (DRS)<br>(3) Metrom Rail Wheel Detection Modules (WD)<br>(12) Metrom Rail Track Integrity Sensors (TIS)<br>USB for data retrieval and software updates<br>Custom inputs available |
| <b>Radio Antenna:</b>             | ¼ wave whip with 4 radials for ground plane  |
| <b>LRW Enclosure:</b>             | 25 x 18 x 16 Formed aluminum case with heat isolation membrane   |
| <b>Radio Message Time:</b>        | 32 MB approximately 30 minutes of talk time  |
| <b>Fault Codes:</b>               | Battery Low, Battery Dead, AC Off, Hardware Failure, Sensor Failure  |
| <b>Data Log Time:</b>             | 30 days of data  |
| <b>Data Log Type:</b>             | Total On Time, AC or DC powered, Data Acknowledgements, Max and Min Temperature, Battery Condition, Battery Voltage, Battery Charge Rate, Interrogations, Sensor or Hardware Failure   |
| <b>Surge Protection Module:</b>   | 10,000 Volts, 5,000 Amps – 10 cycles with no degrading<br>(8) inputs per module  |
| <b>Battery Charger:</b>           | 5 Amps, temperature compensated with internal monitoring   |
| <b>Input Connections:</b>         | (8) Brass hose barbs for 1" diameter hose  |
| <b>Battery:</b>                   | 12 VDC – 40 AH maintenance free  |

